



CodeVu™

Affordable, high-speed camera sensor for accurate date code inspection

Camera Sensor for Date Code Inspection

The TapTone CodeVu camera sensor is a non-contact inspection module designed to visually inspect containers for the absence or presence of date codes, lot codes or batch codes. The sensor includes a high-speed digital camera and diffuse LED light housed in a stainless steel enclosure. The sensor mounts on a remote variable-height stand. The CodeVu sensor is compatible with any TapTone platform and can be added to existing TapTone systems as an optional inspection.

Benefits

- Low-cost camera inspection at production line speeds
- No tools required for change-overs
- Simple height adjustment
- Easy operation using a color touch screen and icon driven menus
- USB Port to download images
- Container teach-in

Applications

- Food cans
- Dairy containers
- Beverage containers
- Carbonated and LN2 dosed beverages
- Household chemicals
- Nutraceutical products
- Personal care & cosmetics

How It Works

The CodeVu sensor uses vision technology to inspect the containers after they pass by the ink or laser coder. A good container is passed through the sensor and the image is stored in the camera. The sensor's inspection algorithm counts the number of "targets" present within the inspection window of the good container. As the production containers pass through the sensor, the high speed camera takes an image at up to 6,000 frames per minute. The image of the production containers are then compared to the image of the good container to determine the absence or presence of the code based on the number of "targets" detected by the camera. Containers that do not match the good image are rejected. The CodeVu sensor can be used to detect missing codes on glass, plastic and metal containers.

Compatible with any TapTone Control Platform!



Can end with date code



Can end missing date code

SYSTEM SPECIFICATIONS

General Specifications

Operating Speed (max)	2,000 containers per minute
Maximum Container Width	170 mm (6.75 in)
Power Requirements	Voltage: 10-30 VDC (Typical 24 VDC) Current: 500mA maximum (exclusive of I/O load)
Operating Conditions	Stable Ambient Temperature: 0° - 50° C (32° to 122° F) Relative Humidity: 0 – 95% maximum, non-condensing
Weight:	9.95 kg (22 lbs)
Trigger Sensor	10-30 VDC, PNP Sourcing Output
Acquisition Time	Frames Per Minute: 6000 max
Light Source	Five high-intensity LEDs, red, diffused acrylic sealed window
Lamp Connection	4-pin Euro-fast (M12) male socket
Lamp Construction	Housing; nickel-plated aluminum or 316 stainless steel (optional)
Lamp Rating	Nickel-plated model: NEMA 4, IP68
Lamp Useful Life	50,000 hours (5.7 years) LED ON time before 30% output reduction

Material & Control Enclosure

Display	LCD color display with integrated touch screen 68.5 mm (2.7 in). Water tight when sealed cover installed, trans-reflective type
Environmental Rating	Stainless steel, NEMA 4X, IP67 rated
Construction	Box: 304 stainless steel housing
Mounting	Angled pedestal stand, 304 stainless steel, tripod base, adjustable height range 241 mm (9.5 in)

Software & Networking Capabilities

- Password protected (sensor lock)
- USB 2.0 Host 8-pin Euro-fast (M12) female connector Optional Euro to USB cable required for USB thumb drive feature



49 Edgerton Drive • North Falmouth, MA 02556 USA

P: +1 508.563.1000

F: +1 508.564.9945

E-Mail: taptone@teledyne.com

10/2014 Specifications subject to change without notice.

TAPTONE is a registered trademark of Teledyne Instruments, Inc. Copyright 2014, TELEDYNE TAPTONE.

CodeVu Sensor

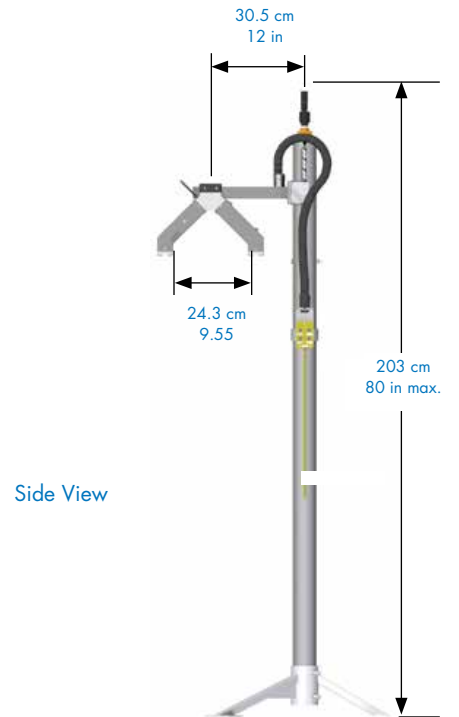
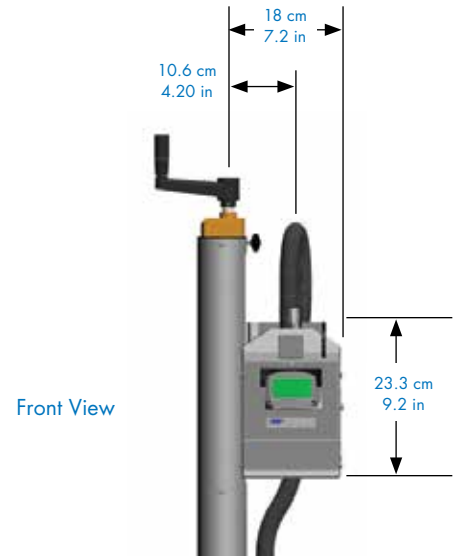

CodeVu Sensor | Compatible Systems

- T100
- T550
- T4000 HMI

The CodeVu Sensor can also be added to existing systems as an upgrade. Sensor requires TapTone user interface for operation.

www.TapTone.com